



DK-12 PRESENCE SENSOR INSTRUCTION MANUAL

**B.E.A., Inc. • 300 South Main Street • Pittsburgh, PA 15215 • USA
Tel. 412-782-5150 • Tel. 800 5 BEA INC • Fax 412-782-5154**

**This manual can be downloaded from our website in PDF format: www.beainc.com.
Requires Adobe Acrobat Reader.**

DK-12 PRESENCE SENSOR

The DK-12 is an active infrared presence sensor which is used for activation or safety on automatic pedestrian and industrial swinging doors, sliding doors, overhead doors, and low-energy doors designated for handicapped accessibility. The DK-12 projects a pyramid shaped pattern that extends to the floor. It will automatically adjust itself upon initial programming to compensate for things such as bright light, shiny floors, various colors of carpeting, etc. It also has a fine tuning adjustment to allow for the most extreme environments.

For smaller openings, the DK-12's zone can be reduced by shutting off one or two of the four zones available, making it ideal for narrow swing doors. On large openings, a single sensor can be used when the desired detection field is at or under 6 feet wide. When required detection coverage is over 6 feet, two DK-12 units should be used.

Because it is microprocessor driven, the DK-12 has the ability to be programmed and to adapt to changing environments. When the immediate area around a doorway gets cluttered with items that should not be there grocery carts, wheelchairs, vending machines, etc., the DK-12 will see these unwanted objects and begin to learn the object and resume normal operation after a preset time delay expires. This is known as self-adaptation, and is adjustable from 30 seconds to 25 minutes.

These features, coupled with a vandal proof design, make the DK-12 presence sensor a practical solution to many varied applications.

DK-12 TECHNICAL SPECIFICATIONS

Installation height	6.3' to 10.0'
Wide detection pattern	6' W x 4' D (see pattern chart)
Narrow detection pattern (center, left, right)	2.5' W x 3.5' D (see pattern chart)
Asymmetrical detection pattern (left, right)	4' W x 4' D (see pattern chart)
Mounting angle	20° - 26° - 32°
Power supply	12 - 24 V AC or DC +/- 10 %
Frequency	50 or 60 Hz
Consumption	2 W
Output	SPDT relay
Max. voltage - relay contacts	60 V DC - 125 V AC
Max. current - relay contacts	8 AMP - resistive
Max. Power supply	30 Watts(DC), 125 VA(AC)
Hold time	1 to 10 seconds
Operating temperature	-30°F to 131°F
Immunity	Immune to electrical and radio frequency interference
Cable	3 feet of 6 conductor cable
Weight	1 lb., 11 oz.
Dimensions	11 ¼" L x 2¼" D x 3" H
Material	Aluminum & ABS plastic
Housing color	Black

INSTALLING THE SENSOR

1. Remove the left end cover of the DK-12 sensor, and remove the mounting bracket from the sensor by sliding it out. To do this, loosen the allen head screw as shown below.



2. Select a mounting position for the sensor. For single door or a pair of doors, the sensor should be centered with relation to the door opening. If the DK-12 is used on any door with an opening greater than 6', it is highly recommended to use more than one DK-12. Pattern selections will depend on the door and the mounting position. See the chart and diagram on the following pages for pattern selection.

Double Swing Door (opening over 6')

See page 7 for selecting the pulsing frequency of two DK-12's located next to each other

Double Swing Door (opening less than 6')

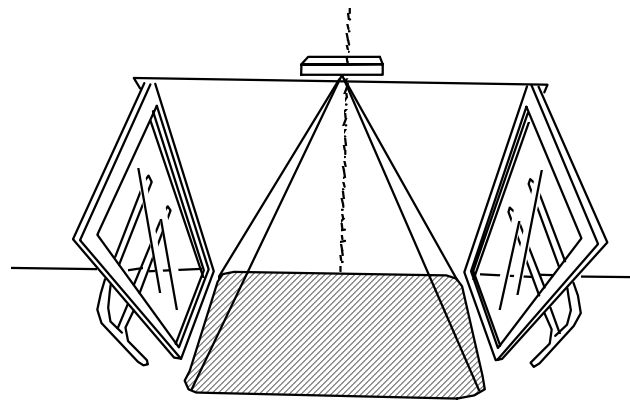
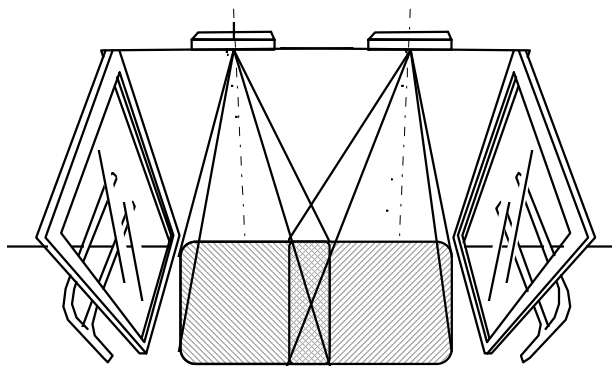

Right Hand Swing Door

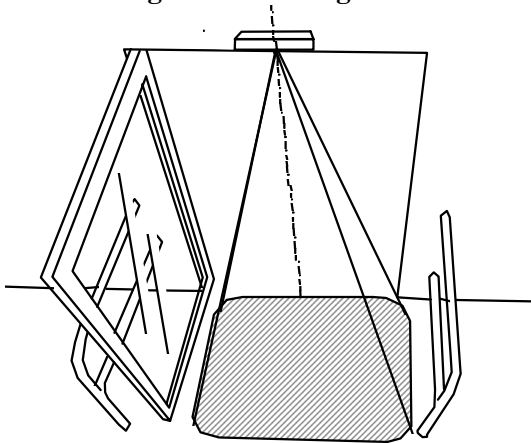

Left Hand Swing Door

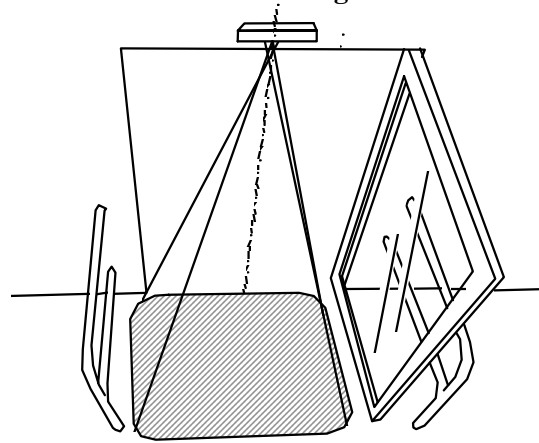

***NOTE:** Be sure that there are no objects within the view of the sensor lenses, such as a door operating arm.

- The mounting bracket may be mounted directly to a header or to the ceiling above. Select the location for mounting, and secure solidly with screws provided.

Wall Mount



Ceiling Mount

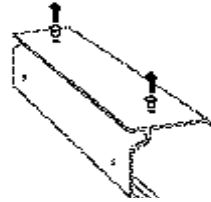

- The installer must provide means for routing wires from the sensor to the inside of the header. The terminal block is located at the left end of the sensor. At the back edge of the left and right end covers, there is a small punch out slot to allow the concealed passage of wire into the sensor. A slot is also provided at the top of the sensor, should wires need to be routed from the opposite end of the sensor. Locate the wire passage hole on the header to keep it concealed. Once the hole is located and drilled, pull the 6-conductor wire from the header to the sensor, and leave a few inches hanging out.

There is no need to drill holes in the aluminum mounting bracket. (voids warranty)

- Mount the sensor back into its bracket as indicated below. The 20° position is considered standard.

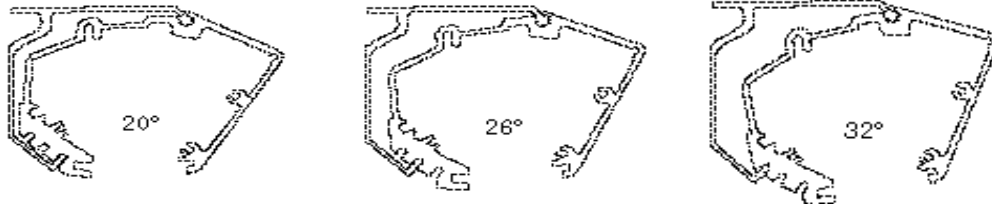

- Tighten set screw on sensor.

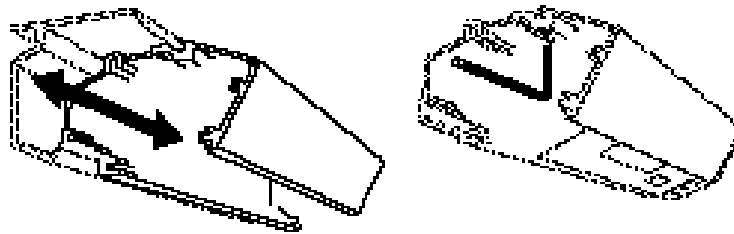

IMPORTANT NOTE: BEA strongly recommends the use of the WHU (weather protection hood) on any DK-12 that is installed outside and is exposed to direct weather. The circuit board of the DK-12 is not waterproof; therefore, it is susceptible to water damage. Any DK-12 that is returned due to water damage will be considered out of warranty.

WIRING THE SENSOR

At the left side of the sensor, remove the 7 pin terminal connector by pulling it straight out. Connect wires as shown below. For complete wiring schematic with specific modules see respective manuals.



TOP VIEW OF CONNECTOR

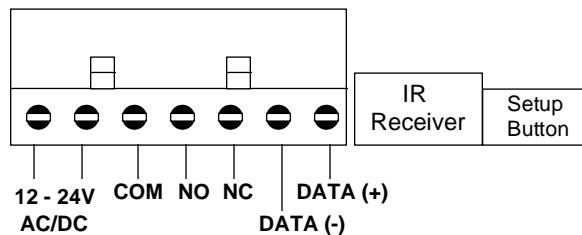

Detector Adjustments

Operation of Remote Control

All adjustments to the DK-12 will be made by BEA's infrared (IR) remote control. The IR remote control enables one to set-up and adjust the detector. The remote uses a modified code, which makes it incompatible with the majority of consumer electronics. Because the end cap blocks the IR receiver after installation, no access code is required.

Since the remote control was designed to operate BEA sensors, its operation is a little different than the usual remote control. To adjust the DK-12, stand to the left of the detector, pointing the remote towards the left side of the detector (without end cap installed) at a distance less than 6 feet from the DK-12. Each adjustment requires pushing two buttons on the remote, a "function" button and then a number. Certain buttons are not used by the DK-12 and if they are pushed, will be ignored.

When one of the "function" buttons is pressed, the indicator LED on the detector will flash rapidly (+/- 10Hz). The flashing of the LED will only occur if a function button is pushed. During the flashing, the detector is waiting for the input of a value between 0 and 9 for its setting. If a value is not entered within 20 seconds after pressing one of the "function" buttons, the detector will go back to the previous settings and the LED will stop flashing. In order to continue with another try, the whole cycle must be started again. For certain functions, not all 10 digits (0-9) are available and if an error is made, the command is ignored and the adjustment must be redone with proper values.

The remote provides access to all the adjustments of the detector:

SENSITIVITY
RELAY HOLD TIME
RELAY MODE
AUTO LEARN TIME

PATTERN
FREQUENCY
SINGLE OR DOUBLE SET-UP
INQUIRY FOR THE ABOVE SETTINGS

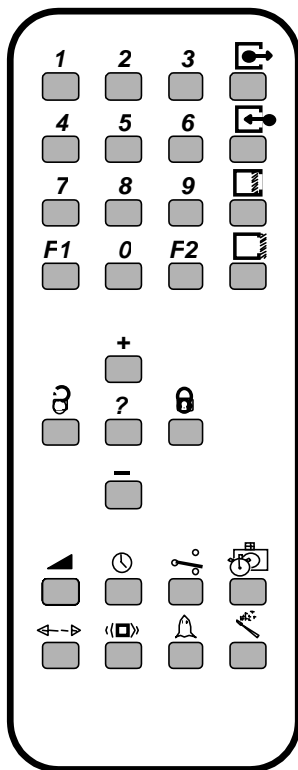

DK-12 PROGRAMMING



The DK-12 has been programmed with factory default settings. They are defined on the remote control chart on the following page. Please review the factory default settings before making any changes to the DK-12. If at any time the factory default settings are appropriate for your application, you **DO NOT** have to change them. Only change the parameters that are needed to customize your application.

With the help of data wires from LO-21/SS-21, the DK-12 has the capability of having two different memory locations: DOOR OPEN and DOOR CLOSED. This feature enables the DK-12 to have different settings for the **pattern selection** and the **sensitivity** in both the DOOR OPEN and DOOR CLOSED positions. All the other settings of the DK-12 remain the same, independent of the position of the door.

DOOR OPEN & DOOR CLOSED memory location capabilities:

Dependent on door position	Independent of door position
Pattern selection	Relay hold time
Sensitivity	Relay mode
	Auto learn time
	Frequency

To program the DK-12, complete the following steps:









1. Review the default settings.
2. Determine which settings need to be changed.
3. Change any setting that is independent of the door position (relay hold time, relay mode, auto learn, frequency):
 - Remove left end cap.
 - Stand within 6' of the left side of the sensor (do not be afraid to stand in the pattern area, but move out of the pattern after making a change).
 - Point the remote control toward the opening (the receiver is located inside of DK-12)
 - Press the function button followed by the number that corresponds to the desired setting.
4. With the door in the CLOSED position, select the pattern size and the sensitivity setting desired.
5. Launch a DOOR CLOSED set-up with the  followed by #1. This will enable the DK-12 to evaluate its surroundings and store it into permanent memory. The LED will flash for approximately 10 sec. and stop once the set-up is complete (see set-up for more details).
6. Place the door into hold open.
7. With the door in the OPEN position, select the pattern size and the sensitivity setting desired.
8. Launch a DOOR OPEN set-up with the  followed by #2. This will enable the DK-12 to evaluate its surroundings and store it into permanent memory. The LED will flash for approximately 10 sec. and stop once the set-up is complete (see set-up for more details).

SET-UP

Once a set-up is launched the LED will flash at 5 Hz for approximately 10 seconds.

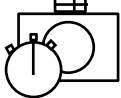
- If the set-up is successful, the LED will go off and the detector will function normally.
- If the set-up is not successful, the LED will continue to flash, but at a lower frequency of 2.5 Hz.
 - Possible problems during setup:
 - a. If a person walks through the detection zone during the set-up, the set-up can be disturbed
 - b. If a very reflective object is placed within 32 inches from the DK-12, it can blind the detector and make the set-up impossible.
 - c. If the set-up that corresponds to the DOOR OPEN state is launched when the door is closed, the set-up will be ignored and vice versa.

Please note: When two DK-12's are installed on the same door, place the end cap on one DK-12 and program the open DK-12. Once the first DK-12 is programmed, install its end cap and remove the second DK-12's end cap and repeat the programming procedure.

Function Buttons	Actions	Factory Settings	LED Status
	<p>SENSITIVITY – Press this key followed by the number button (0-9) of the sensitivity desired. This setting can be selected for both states of the door, DOOR OPEN or DOOR CLOSED.</p> <p>9 – maximum 0 - minimum</p> <p><i>SEE section A on following page for more details.</i></p>	<p>Door closed = 8</p> <p>Door open = 7</p>	LED flashes
	<p>RELAY HOLD TIME – Press this key followed by the number button (0-9) to enter the required hold time.</p> <p>0- 1 sec. 4- 5 sec. 7- 8 sec. 1- 2 sec. 5- 6 sec. 8- 9 sec. 2- 3 sec. 6- 7 sec. 9- 10 sec. 3- 4 sec.</p>	<p>1 sec.</p>	LED flashes
	<p>PATTERN SELECTION – Press this key followed by a number button (1-6) to select the required pattern. This setting can be selected for both states of the door, DOOR OPEN or DOOR CLOSED.</p> <p>1- Wide pattern (ABCD) 2- Wide left pattern (ABC) 3- Wide right pattern (BCD) 4- Narrow left pattern (AB) 5- Narrow center pattern (BC) 6- Narrow right pattern (CD)</p> <p><i>SEE section C on following page for more details.</i></p>	<p>Door closed = 1</p> <p>Door open = 1</p>	LED flashes
	<p>RELAY CONFIGURATION - Press this key followed by a number button (1-4) to select the required relay output desired.</p> <p>1- active output, relay contact open during detection, closed during non-detection 2- passive output, relay contact closed during detection, open during non-detection 3- continuous detection, relay contact always closed 4- continuous non-detection, relay contact always open</p>	<p>Passive</p>	LED flashes
	<p>AUTO LEARN TIME – Press this key followed by a number button (1-9) to select the required auto learn time.</p> <p>0 – 30 sec. 4 – 5 min. 7 – 15 min. 1 – 1min. 5 – 7 min. 8 – 20 min. 2 – 2 min. 6 – 10 min. 9 – 25 min. 3 – 3 min.</p> <p><i>SEE section B on following page for more details</i></p>	<p>1 minute</p>	LED flashes
	<p>FREQUENCY – Press this key followed by a number button (1-2) to select the required frequency.</p> <p>1 – high impulse 2 – low impulse</p>	<p>High impulse</p>	LED flashes
	<p>INQUIRY – Press this button after pressing the button of the parameter that you would like to check. Then count the number of times the LED flashes. This corresponds to the status of the parameter in question.</p>	<p>No setting</p>	LED will flash according to the setting of the parameter in question.
	<p>SET-UP – Press this button followed by a number button (1-3) to launch the desired set-up.</p> <p>1 – Door closed set-up 2 – Door open set-up 3 – Reset factory default settings (can be pressed in either door open or door closed position)</p>	<p>No setting</p>	See SET-UP procedure.

A. SENSITIVITY SELECTION

The sensitivity setting of the DK-12 allows the installer to adjust the size of the pattern selected for both states of the door (DOOR OPEN or DOOR CLOSED).

The sensitivity of the pattern can be different when the door is open and when it is closed. In the DK-12, there is no link between the pattern for DOOR OPEN or DOOR CLOSED. The sensitivity of the pattern is accessible as a function of the state of the door and only the corresponding sensitivity can be adjusted. The DK-12 receives communication from the LO-21 or SS-21 as to the state of the door (open or closed) via the data lines.

- *The max. sensitivity is strongly discouraged for DOOR OPEN if the mounting height is less than 8'.*
- *The sensitivity can be adjusted after doing a set-up without relaunching a set-up.*

B. AUTO LEARN TIME

The Auto Learn Time is the time in which the DK-12 will automatically learn any permanent changes in its field of detection. This time delay begins counting down once a change in the detection zone occurs. If the object is removed from the zone before the time delay has expired the DK-12 will not save it as part of its memory. During the auto learn time the DK-12 will lock on and hold the door in either the open or closed position for the set learn time. Once the auto learn time has expired the DK-12 will do a short reevaluation that takes +/- 10 seconds. If someone walks through the pattern during this evaluation, it will fail and the DK-12 will stay triggered until it has a stable background to learn. After the DK-12 has learned the object, it will resume its normal function.

- *If the pattern of the DK-12 is interrupted during the auto learn time, the auto learn time will continue to count down without interruption.*

C. PATTERN SELECTION





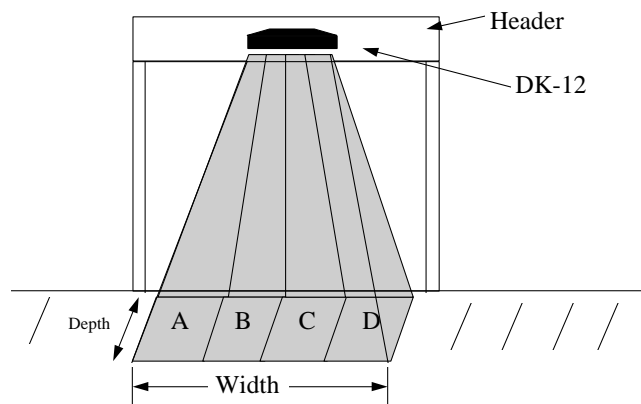

The DK-12 detection zone is made up of 4 small zones placed next to each other, perpendicular to the door. The 4 zones are shown in the diagram below. There are 6 different patterns that are possible with combinations of the 4 detection zones. Please refer to the chart on the following page for the dimensions of the DK-12 detection zones at different mounting heights and mounting angles.





The shape of the pattern can be different when the door is open and when it is closed. In the detector, there is no link between the pattern for the open door and the pattern for the closed door. The shape of the pattern is accessible as a function of door state and only the corresponding shape can be adjusted. The DK-12 receives input from the LO-21 or SS-21 as to the state of the door via the data lines.





- *After any change in the shape of the pattern, it is necessary to relaunch a new set-up for both the open and closed positions of the door.*

PATTERN CHART

Mounting Height 7'3"	Wide Pattern ABCD	Narrow Pattern BC	Narrow Pattern AB or CD	Asymmetrical Pattern ABC or BCD
	width x depth	width x depth	width x depth	width x depth
ANGLE: 20°				
 #9	5' x 3'3"	2'3" x 2'3"	2'6" x 3'	3'6" x 3'3"
 #0	4' x 2'6"	2' x 2'	2' x 2'3"	2'3" x 2'
ANGLE: 26°				
 #9	5' x 4'3"	2.3' x 4'	2'6" x 3'6"	4' x 4'
 #0	4' x 3'3"	1'6" x 2'6"	2' x 2'6"	3' x 3'3"
ANGLE: 32°				
 #9	6' x 6'	2'3" x 5'	2'6" x 4'	3'6" x 5'6"
 #0	3'6" x 4'3"	2' x 4'	2' x 3'6"	2'3" x 4'

Mounting Height 8'3"				
ANGLE: 20°				
 #9	5'3" x 3'6"	2'6" x 3'3"	2'6" x 3'	3'6" x 3'6"
 #0	3'3" x 2'6"	2' x 2'3"	2' x 2'3"	2'3" x 2'6"
ANGLE: 26°				
 #9	5'3" x 5'6"	2.3' x 3'6"	2'3" x 3'3"	4' x 3'6"
 #0	3'3" x 2'6"	1'3" x 2'3"	2' x 2'3"	2'3" x 2'6"
ANGLE: 32°				
 #9	5'6" x 6'9"	3' x 6'	3'3" x 5'6"	4' x 6'9"
 #0	3'3" x 4'6"	1'6" x 4'	1'6" x 4'	3' x 4'

Mounting Height 9'6"				
ANGLE: 20°				
 #9	6'6" x 4'6"	2.3' x 4'6"	2'3" x 4'3"	4'3" x 4'6"
 #0	4' x 3'3"	1'6" x 3'3"	1'6" x 2'6"	2'3" x 3'
ANGLE: 26°	do not use			
ANGLE: 32°	do not use			

NOTE: The above dimensions are given as references only! They are to aid in pattern selection.

DK-12 TROUBLE SHOOTING GUIDE

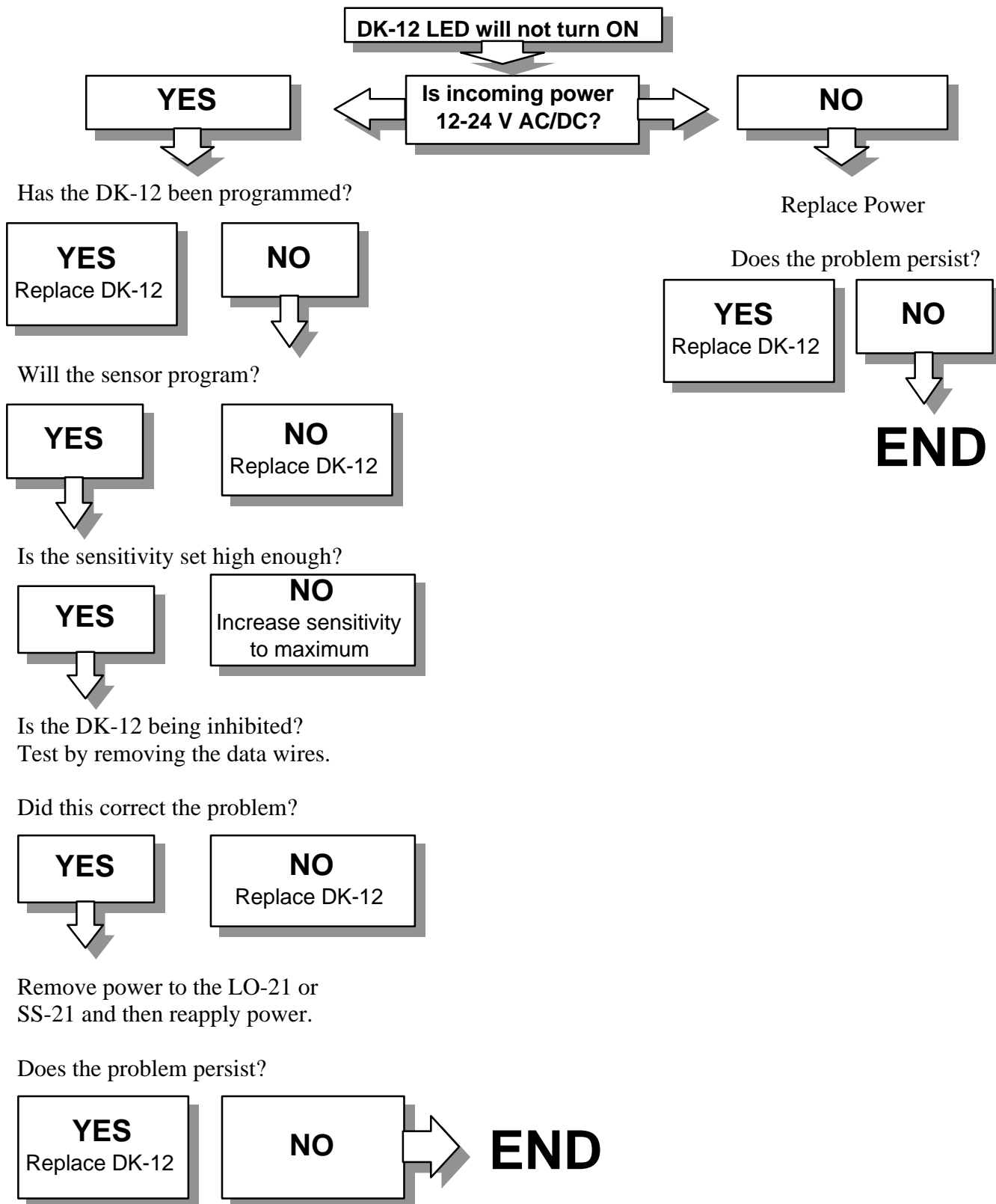

DK-12 TROUBLE SHOOTING GUIDE

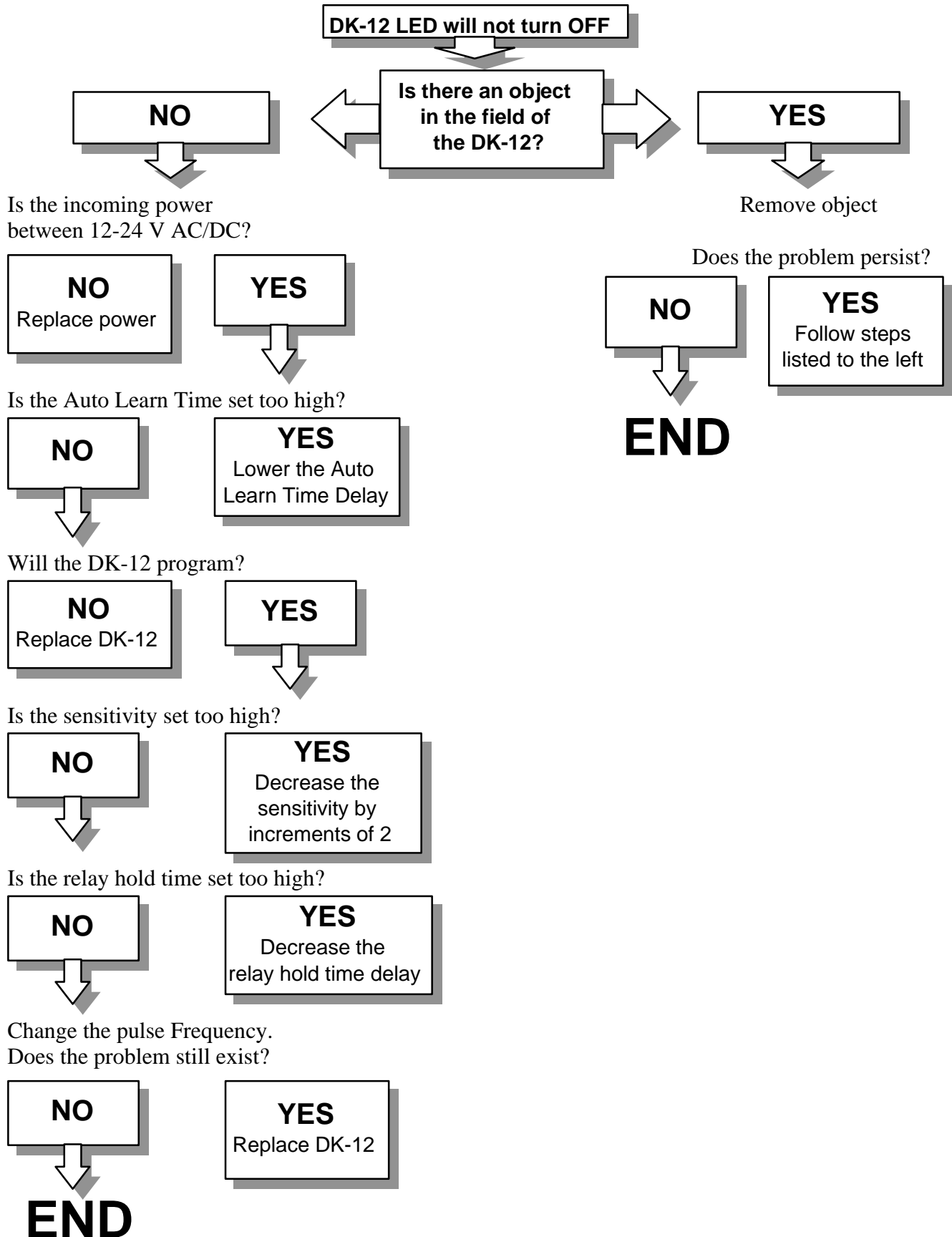

DK-12 TROUBLESHOOTING GUIDE

DK-12 LED flashes very slowly and door remains open or closed

- Relay is in fixed ON position. Select a relay output of active or passive.

DK-12 LED flashes very slowly and door has no safety

- Relay is in the fixed OFF position. Select a relay output of active or passive.

DK-12 LED flashes very fast

- DK-12 has only received the first half of a two button remote input. Enter second half of code or wait 20 seconds for LED to go out.
- If LED fails to go out, power the DK-12 down and then power it back up.

DK-12 LED Flashes at a medium speed (4 flashes per second)

- DK-12 is programming. Stay out of the DK-12's field of view.

DK-12 LED flashes at 1 flash per second

- DK-12 has failed to program due to interference during programming. Clear the pattern area and reprogram.
- If DK-12 fails to program again, place a black mat on the floor in the DK-12's field of view and reprogram. Once programmed, remove the mat and let the DK-12 self adapt for the set Auto Learn Time.

DK-12 will not go into door open pattern or inhibit during closing

- Check that the data wires are connected in the proper polarity.
- Check that the SS-21 or LO-21 is powered and operating.
- Check that the motor polarity operator is correct to the SS-21 or LO-21
- Replace the LO-21 or SS-21 first; if this does not correct the problem, replace the DK-12.

If after troubleshooting a problem, a satisfactory solution cannot be achieved, please call B.E.A., Inc. for further assistance during Eastern Standard Time at
1-800-523-2462 from 7am - 5pm or 1-800-407-4545 from 5pm - midnight & weekends.

DO NOT leave any problem unresolved. If you must wait for the following workday to call B.E.A., leave the door inoperable until satisfactory repairs can be made. **NEVER** sacrifice the safe operation of the automatic door or gate for an incomplete solution.